

# Fast unfolding of communities in large networks

R. Lambiotte  
Institute for Mathematical Sciences  
Imperial College London

with V.D. Blondel, J.-L. Guillaume and E. Lefebvre

Imperial College  
London

100 years of living science

100

# Contents

1. Complex networks
2. Communities and how to detect them
3. Our algorithm
4. Advantages
5. Conclusion

Paper available at: arXiv:0803.0476v1  
C++ and matlab code available at <http://findcommunities.googlepages.com>

# Networks

Mathematical tool to describe systems composed of elements and of the relations between them (directed or not)

Internet

Transport networks

Power grids

Protein interaction networks

Food webs

Metabolic networks

Social networks

Etc.

# Complex networks

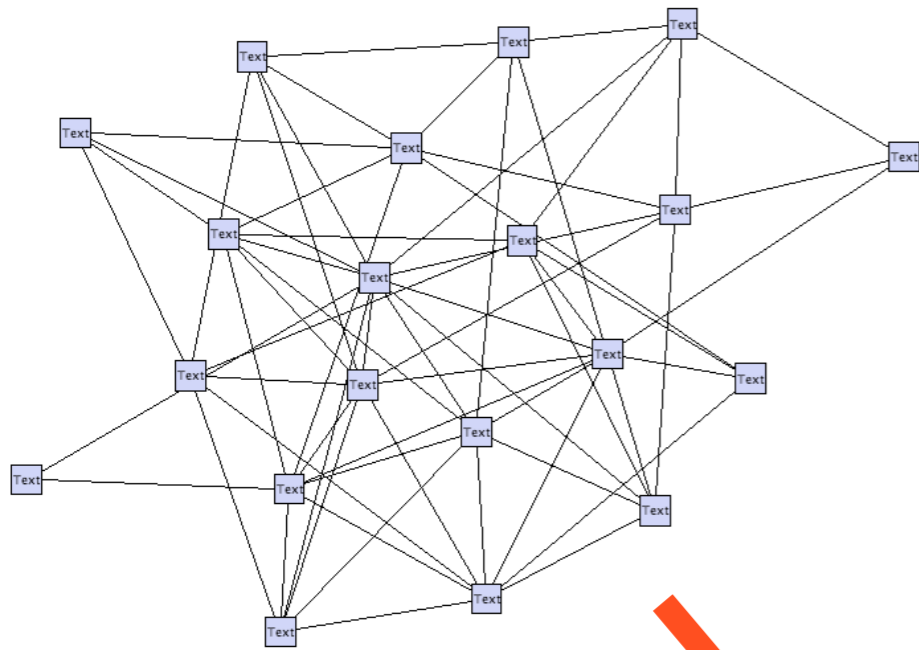

Random topology:  
Mean Field

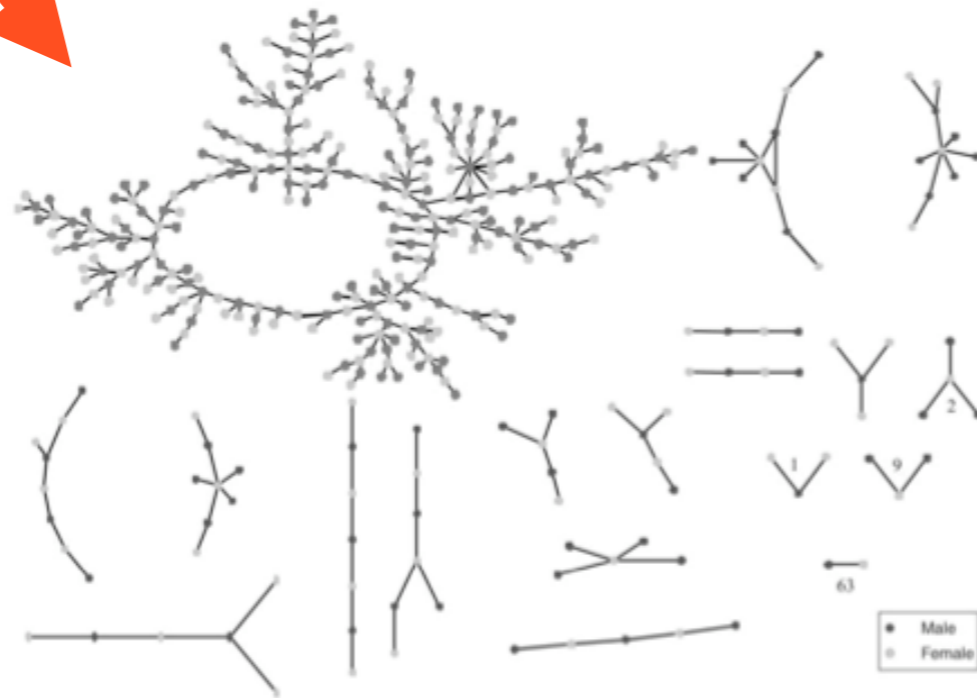
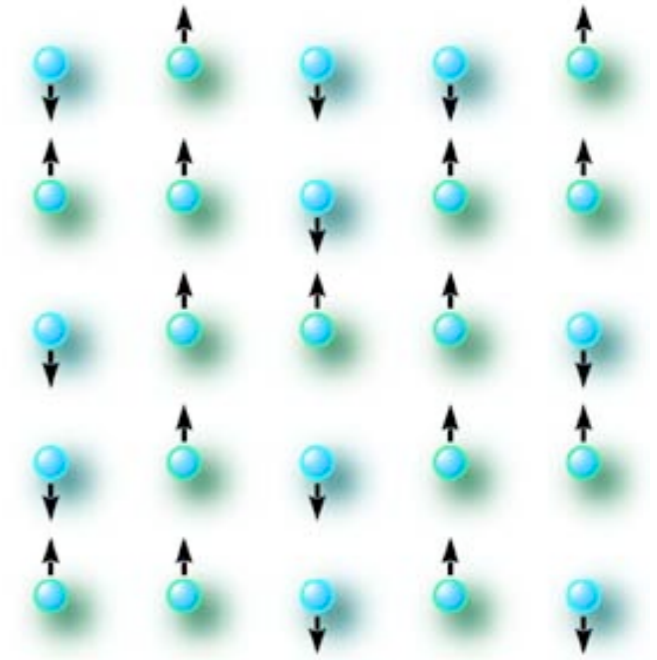

FIG. 2.—The direct relationship structure at Jefferson High



Regular lattice



Chains of Affection: The Structure of Adolescent  
Romantic and Sexual Networks:  
Peter S. Bearman, James Moody and Katherine Stovel

# Complex networks

When composed by a large number of nodes and links



## Statistical approach

- Degree distribution: overpopulated tail (scale-free or stretched exponential)
- Density of triangles (local structure; transitivity)
- Small “Diameter”
- Correlation of the degrees around one link
- Etc.

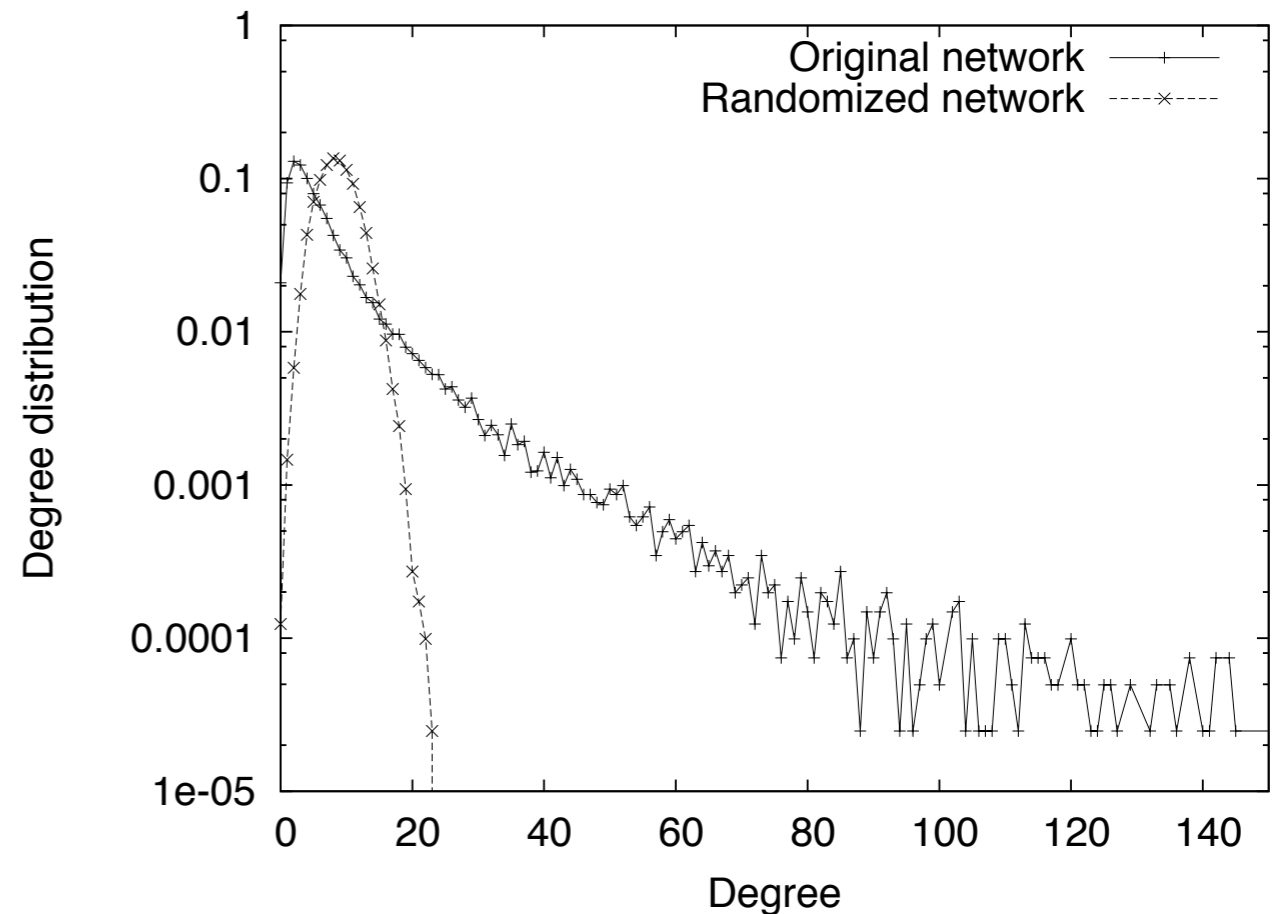

Network of collaboration from the arXiv (1995-2005). Around 40000 nodes.

# Complex networks and Dynamics

How does the topology affect the dynamics taking place on it (diffusion, synchronisation, etc.)

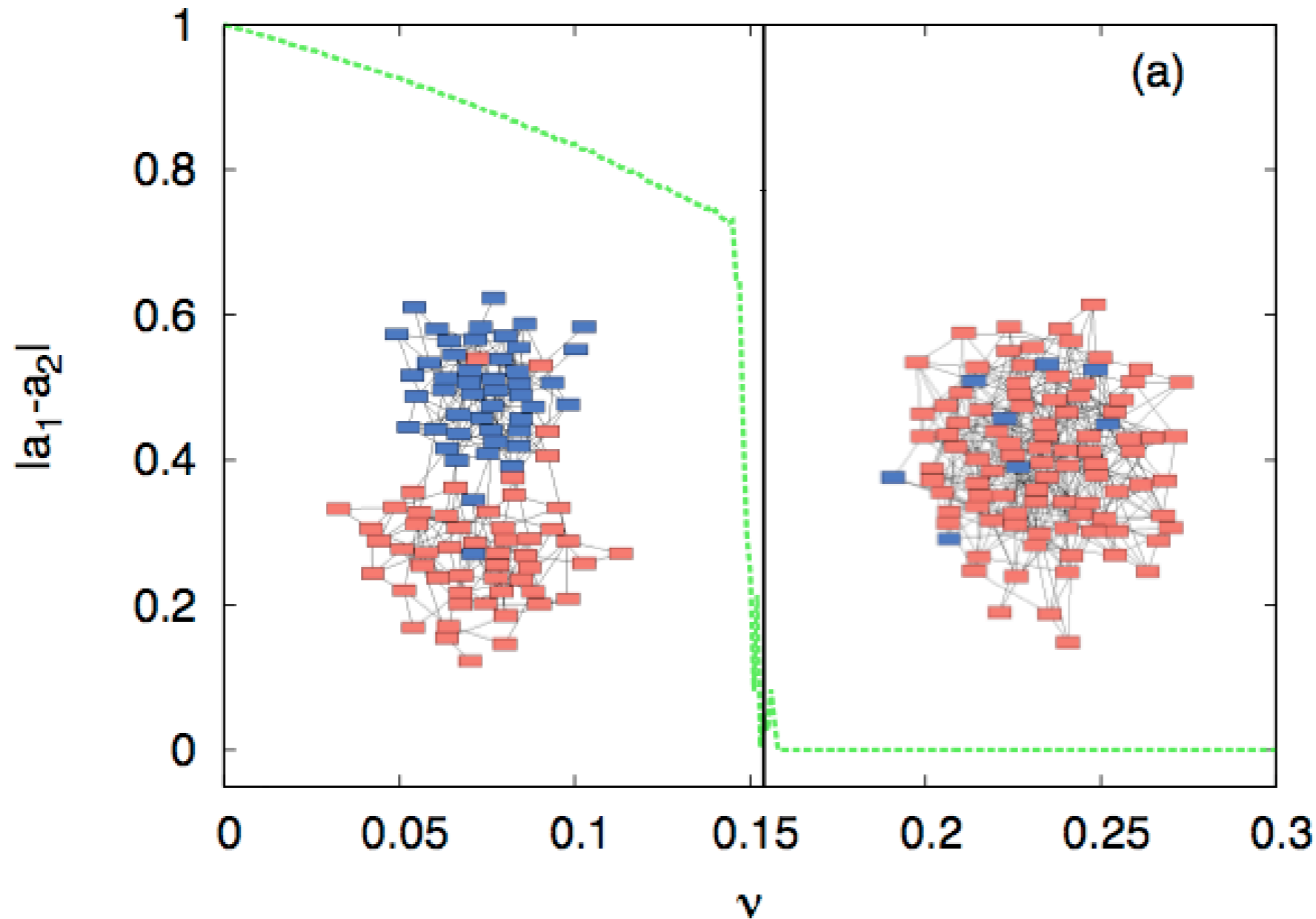

# Modular Networks

Most networks are very inhomogeneous and are made of modules: many links within modules and a few links between different modules

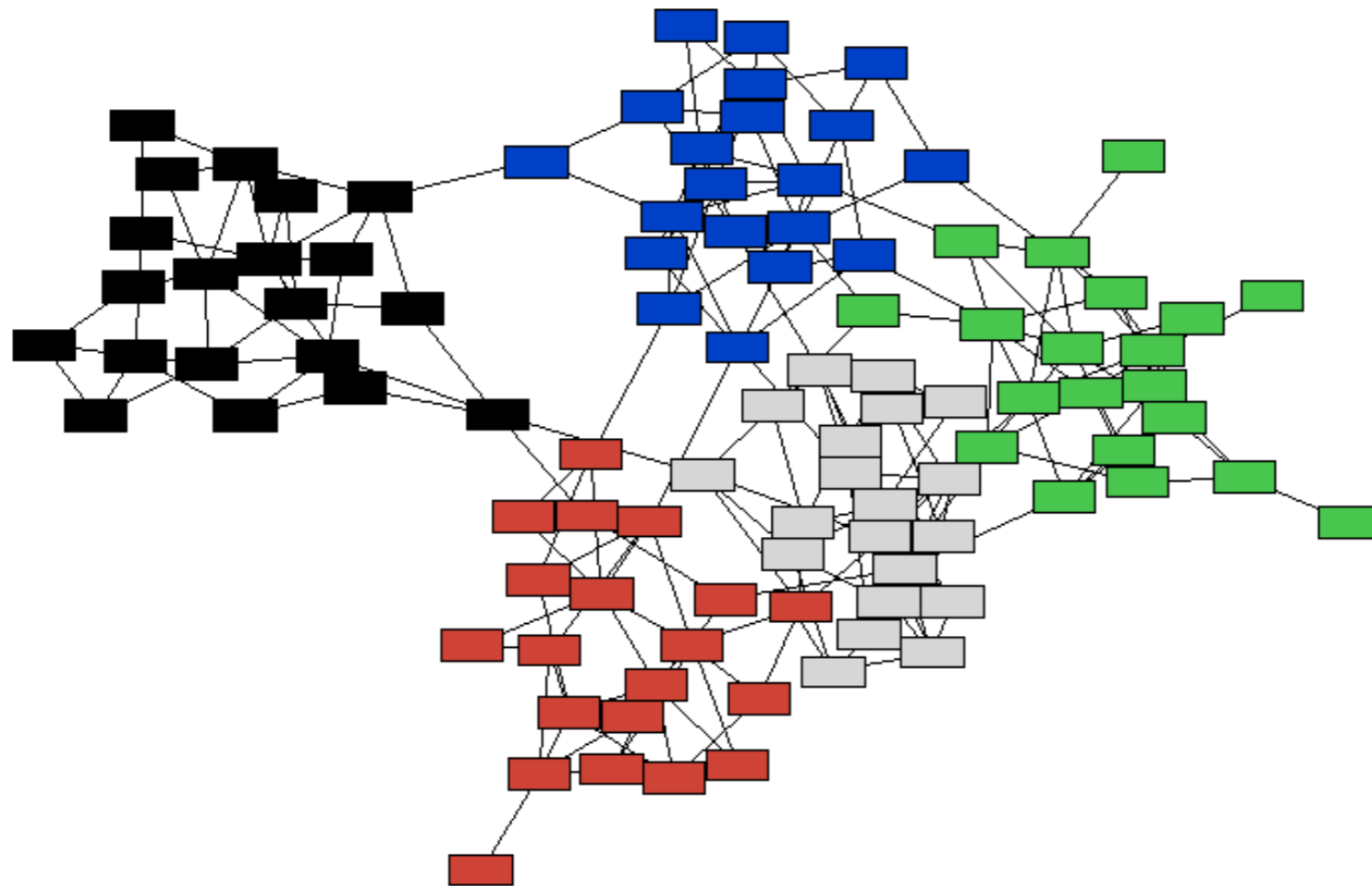

# Modular Networks

Networks have a hierarchical structure: communities within communities

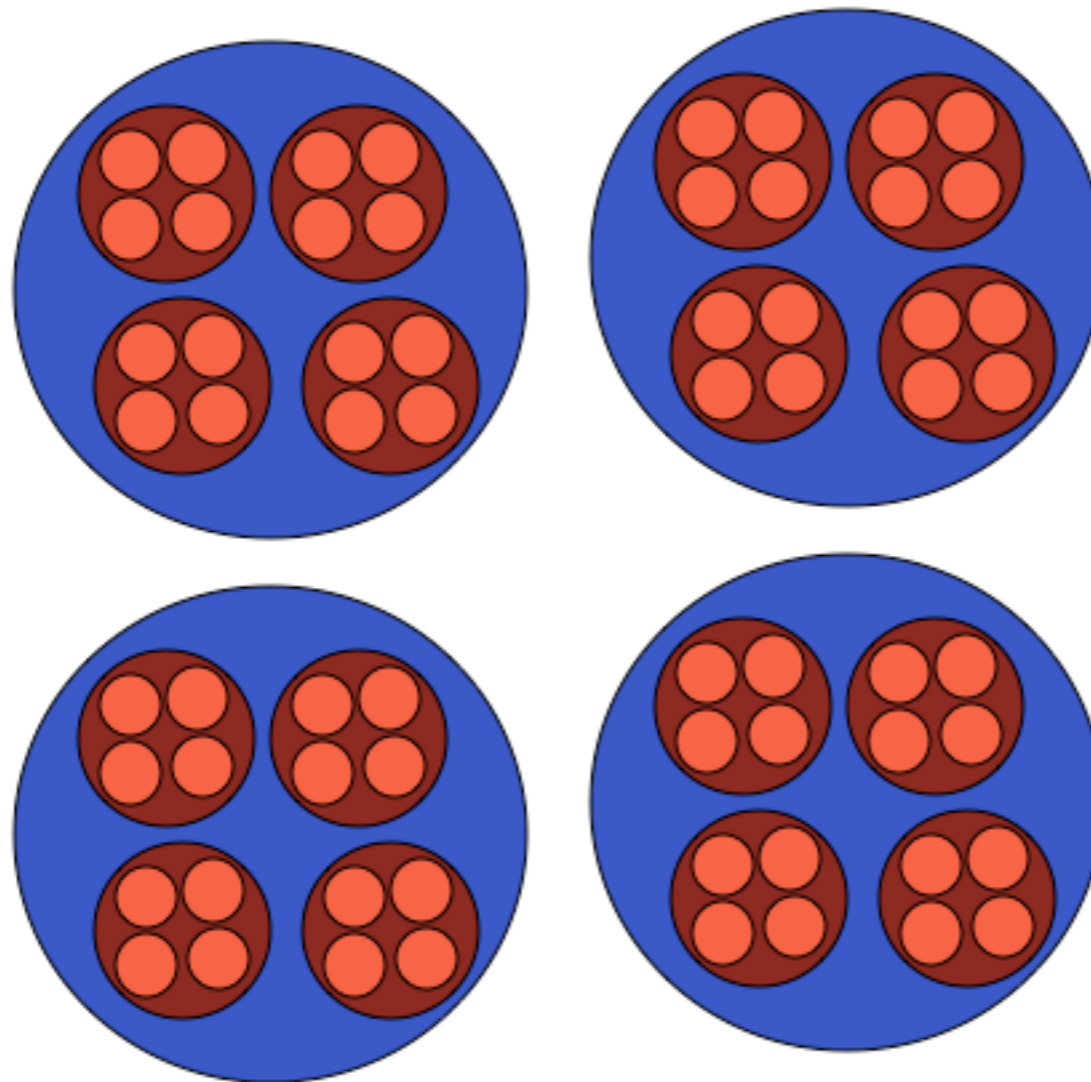

# Modular Networks

Uncovering communities/modules helps to understand the structure of the network, to uncover similar nodes and to draw a readable map of the network (when N is large).

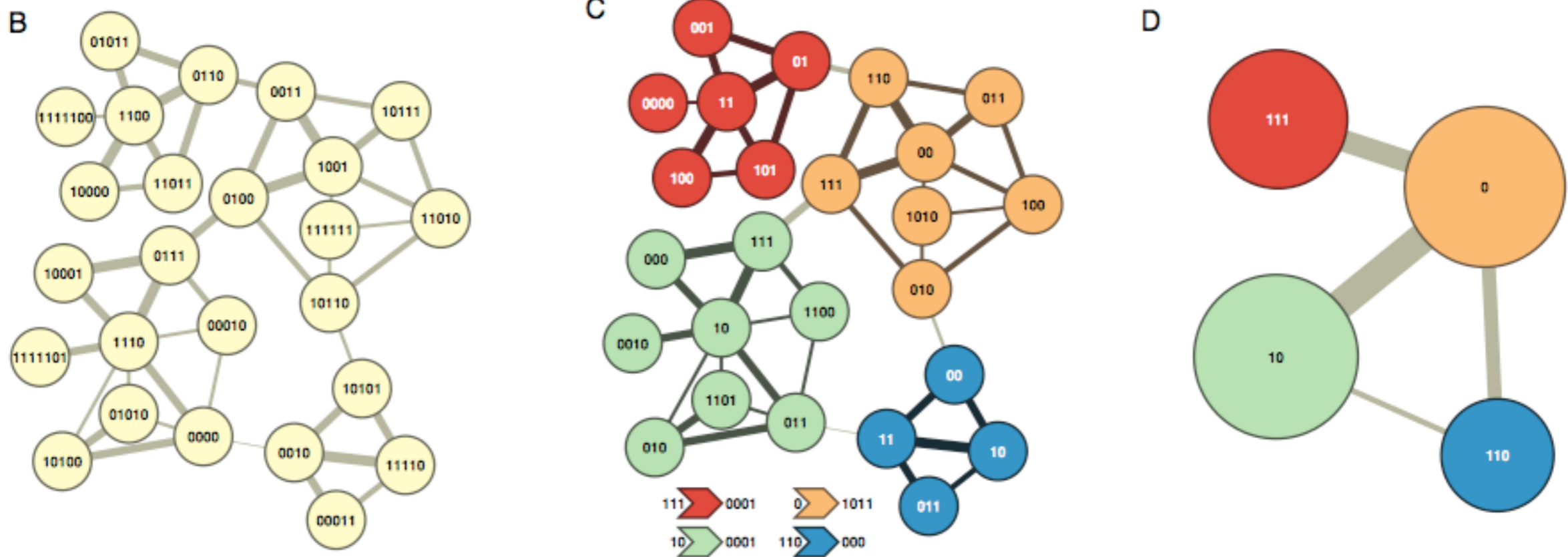

Find a partition of the network into communities

Coarse-grained description

# Modular Networks

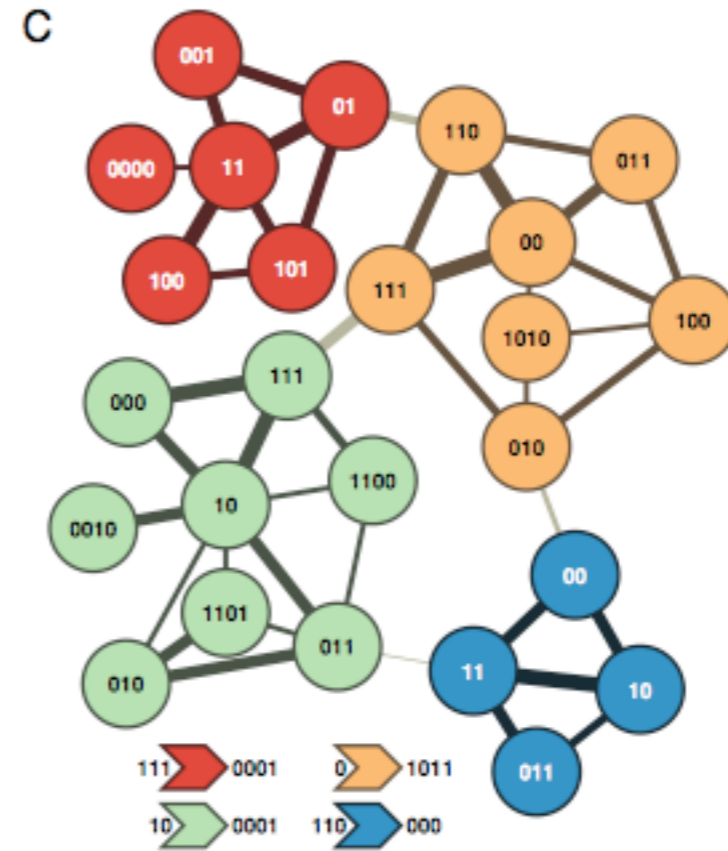
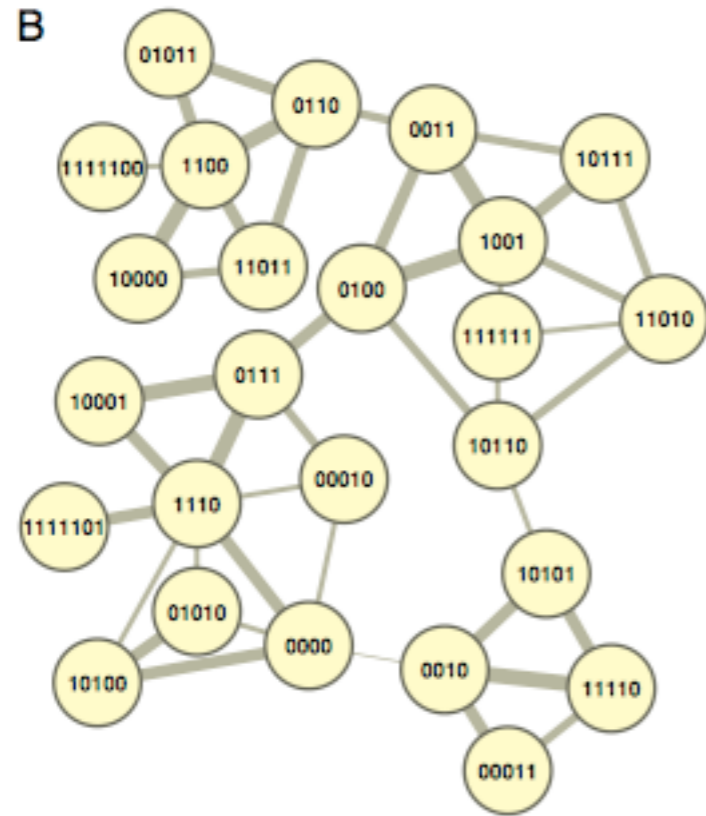

As rapid and accurate as possible

Unsupervised

# Modularity

Modularity: function which measures the quality of a partition

$Q = (\text{number of edges within communities}) - (\text{expected number of such edges})$

Larger values of  $Q \Rightarrow$  stronger community structure

Comparison of the network with a null model  
(randomised model)

# Modularity

Modularity: function which measures the quality of a partition

Let us focus on a weighted network and attribute to each node a community  $C_i$

$$Q = \frac{1}{2m} \sum_{i,j} \left[ A_{ij} - \frac{k_i k_j}{2m} \right] \delta(c_i, c_j)$$

$A_{ij}$  weight of the edge between  $i$  and  $j$

$k_i = \sum_j A_{ij}$  degree of  $i$

$m = \frac{1}{2} \sum_{ij} A_{ij}$  total weight

$$Q \in [-1, 1]$$

$$Q = \frac{1}{2m} \sum_{i,j} \left[ A_{ij} - \frac{k_i k_j}{2m} \right] \delta(c_i, c_j)$$

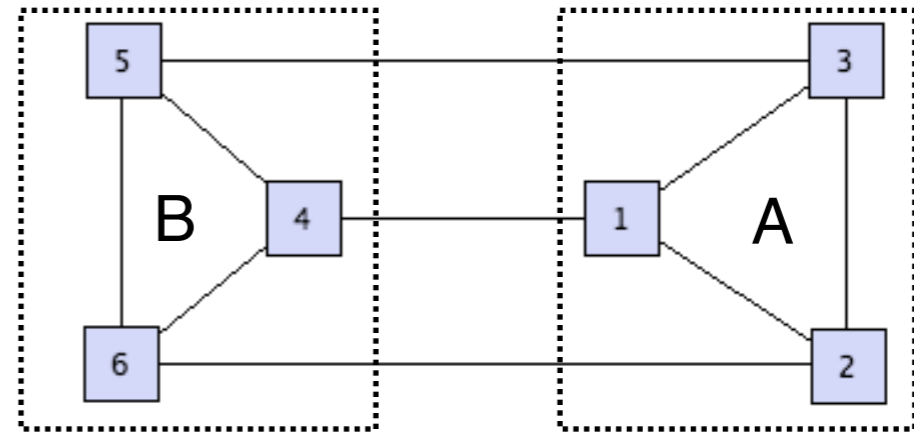
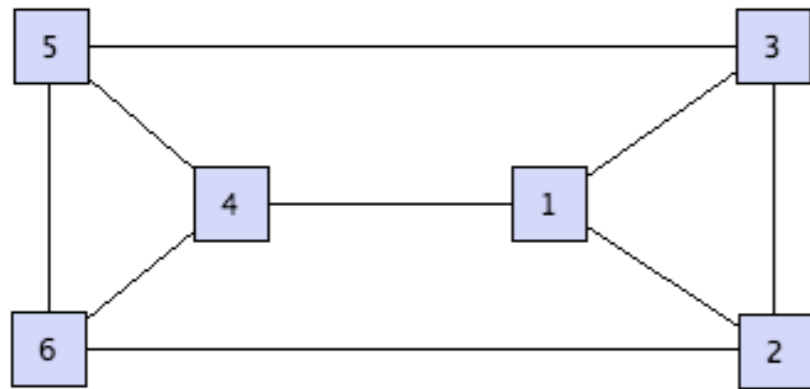

The degree is the same for each node: 3

The total number number of links is: 9

In community A, 6 pairs of nodes  $i,j$ , [(1,2),(2,1),(1,3), etc.] with a contribution:  $1-9/18=1/2$

In community A, 3 loops  $i,i$  missing, with a contribution  $-1/2$

$6 (1/2)-3(1/2)=3/2$

Same contribution from community B

Modularity is therefore:

$1/(2 * 9) * 2 * 3/2= 1/6$

# Modularity

Modularity is used to validate the quality of a partition, but also as a quantity to optimise in order to find the best partition: Given a network, what is the partition with the highest value of  $Q$

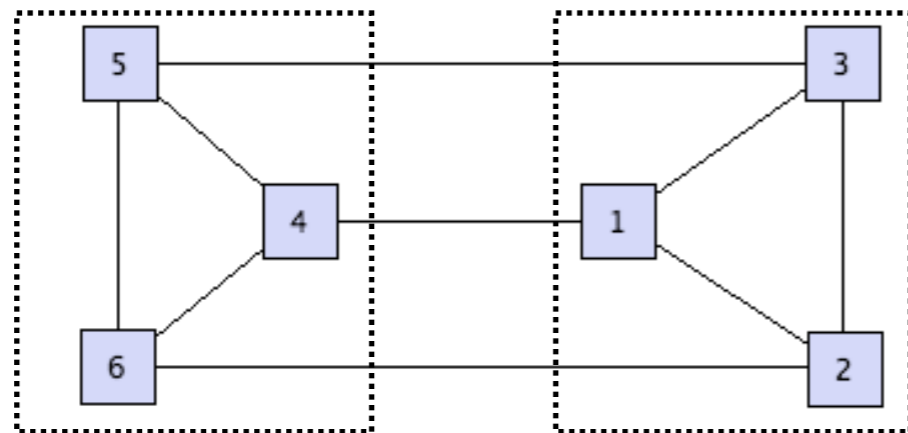

$$Q_{max} = 1/6$$

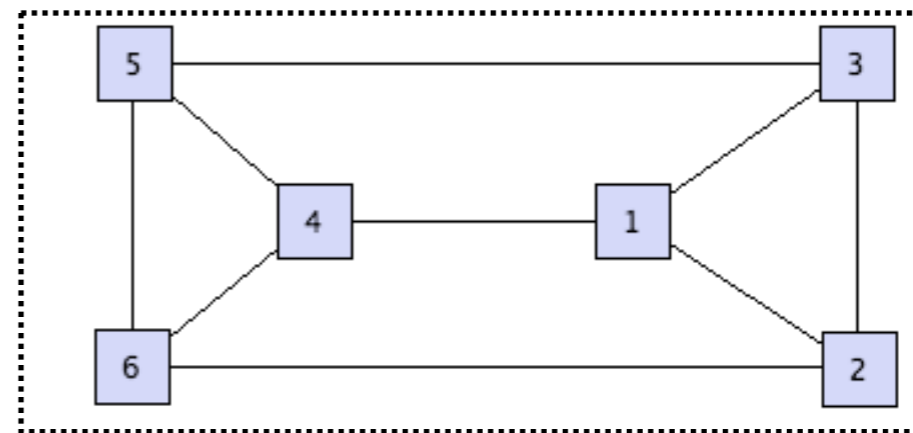

$$Q = 0$$

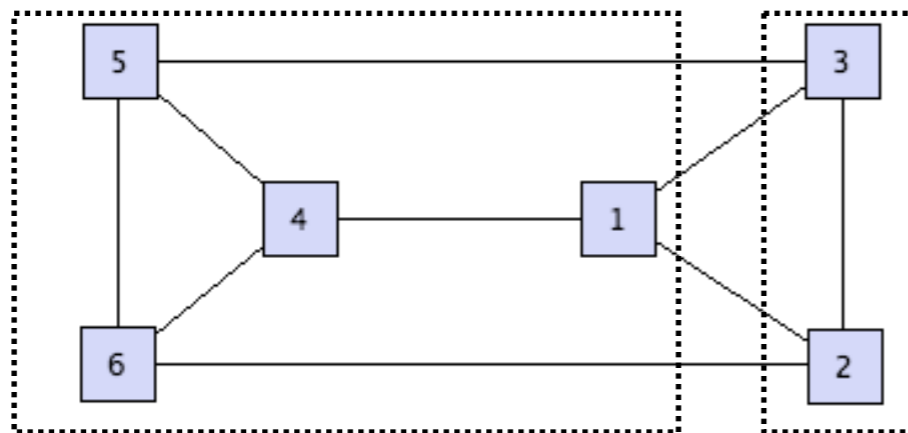

$$Q = 0$$

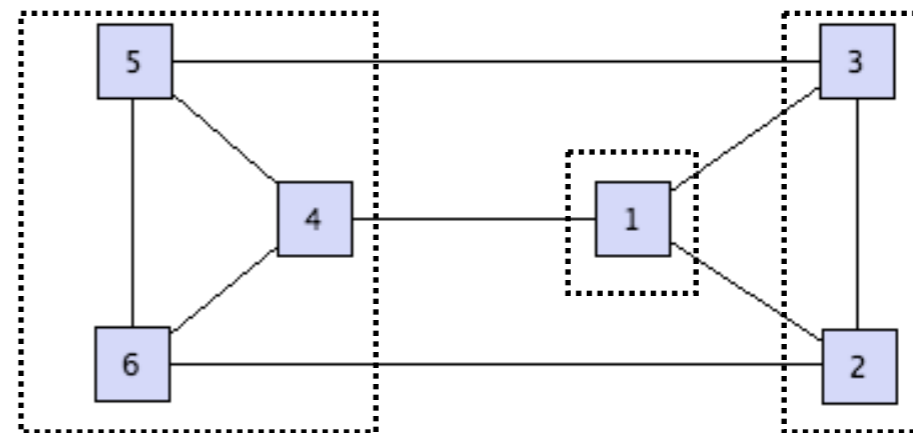

$$Q = 1/18$$

# Modularity

Modularity is used to validate the quality of a partition, but also as a quantity to optimise in order to find the best partition: Given a network, what is the partition with the highest value of  $Q$

Finding an exact answer is not possible in large (and less regular) networks

=> need for algorithms which find *good partitions* in short times

The largest network studied so far is a Japanese social networking systems of about 5.5 million (Wakita and Tsurumi) to be compared with:

Facebook has about 64 million active users

Vodafone has about 200 million customers and Google indexes several billion web-pages.

# Our algorithm

The algorithm is based on two steps that are repeated iteratively.

First phase: Find a local maximum

- 1) Give an order to the nodes (0,1,2,3,....., N-1)
- 2) Initially, each node belongs to its own community (N nodes and N communities)
- 3) One looks through all the nodes (from 0 to N-1) in an ordered way. The selected node looks among its neighbours and adopt the community of the neighbour for which the increase of modularity is maximum (and positive).
- 4) This step is performed iteratively until a local maximum of modularity is reached (each node may be considered several times).

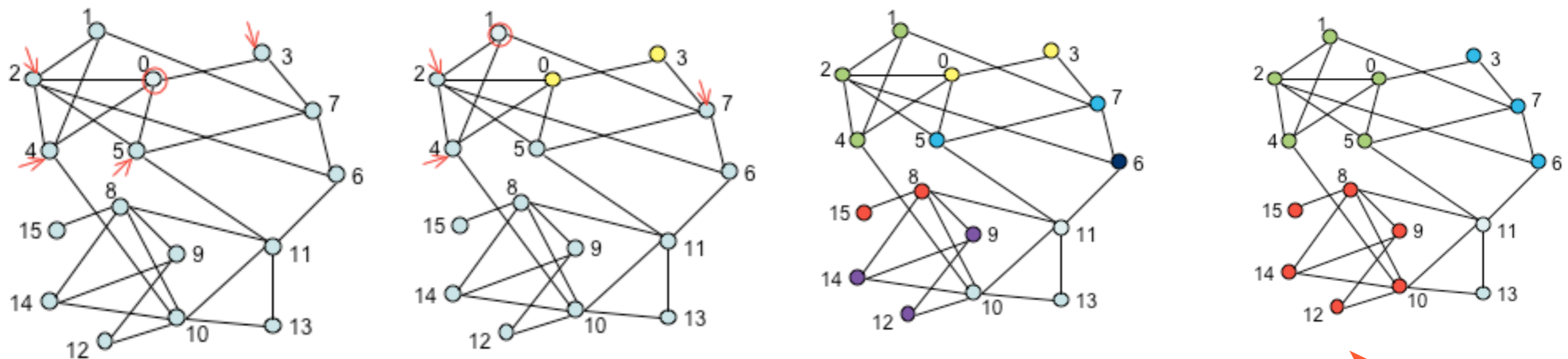

Node 0 moves to the community of Node 3

After N nodes have been considered

After each nodes has been considered 4 times

# Our algorithm

Once a local maximum has been attained, we build a new network whose nodes are the communities. The weight of the links between communities is the total weight of the links between the nodes of these communities.

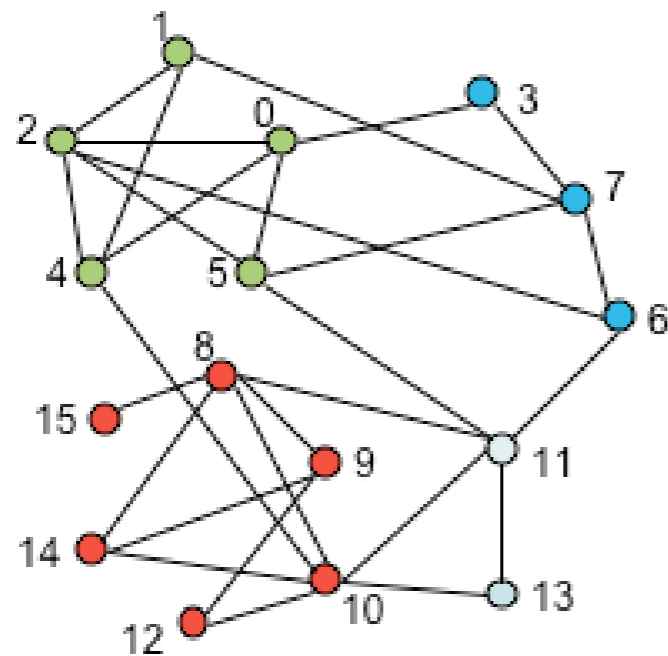

New network of 4 nodes!

Note the self-loops

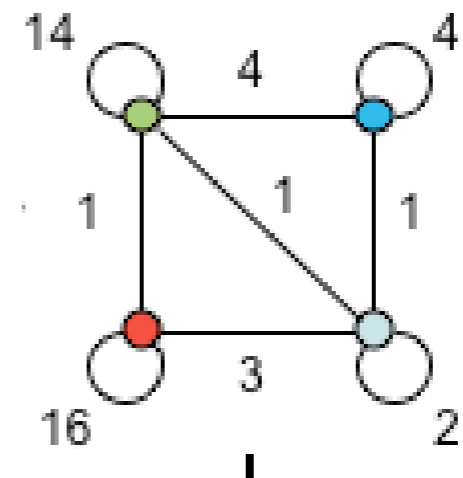

In typical realizations, the number of nodes diminishes drastically at this step.

# Our algorithm

The two steps are repeated iteratively, thereby leading to a hierarchical decomposition of the network.

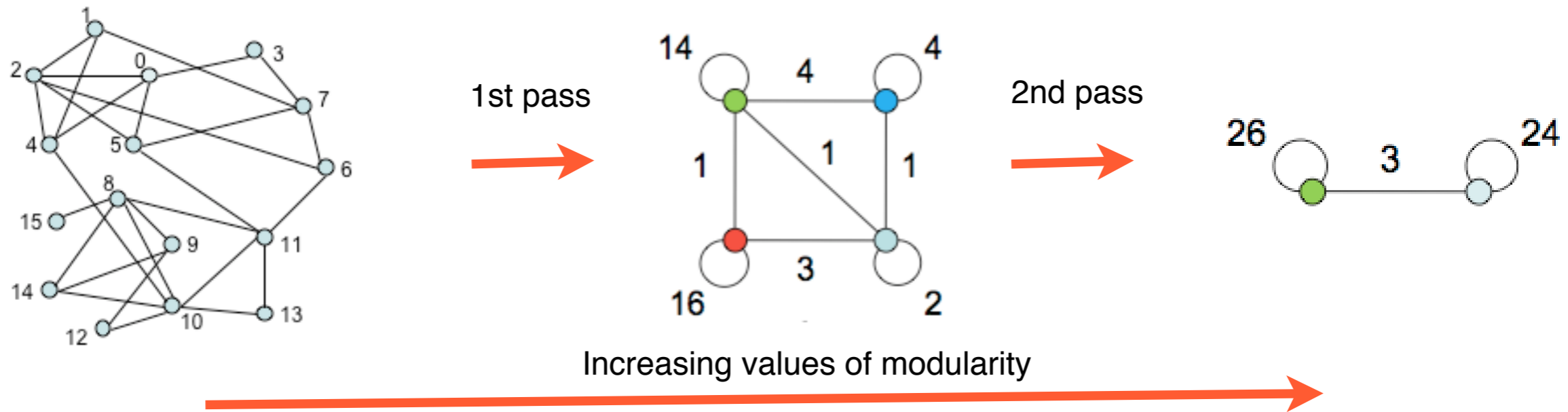

Hierarchical representation

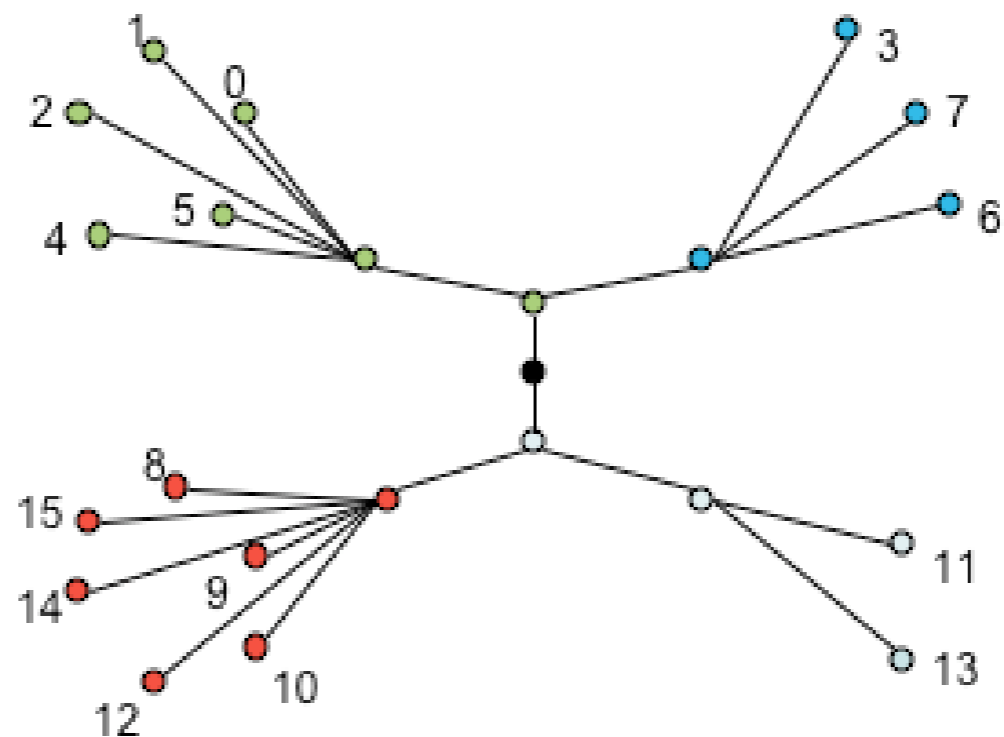

# Advantages

Incredibly simple (local greedy approach) $\Rightarrow$  easy to implement and to improve

# Advantages

Incredibly simple (local greedy approach) $\Rightarrow$  easy to implement and to improve

Very fast!

Largest network: 5.5 million nodes

	Karate	Arxiv	Internet	Web nd.edu	Phone	Web uk-2005	Web	WebBase 2001
Nodes/links	34/77	9k/24k	70k/351k	325k/1M	2.04M/5.4M	39M/783M		118M/1B
CNM	.38/0s	.772/3.6s	.692/799s	.927/5034s	-/-	-/-		-/-
PL	.42/0s	.757/3.3s	.729/575s	.895/6666s	-/-	-/-		-/-
WT	.42/0s	.761/0.7s	.667/62s	.898/248s	.553/367s	-/-		-/-
Our algorithm	.42/0s	.813/0s	.781/1s	.935/3s	.76/44s	.979/738s		.984/152mn

Our only limitation being the storage of the network in main memory

Computer simulations on large ad-hoc modular networks suggest that its complexity is linear on typical and sparse data

Clauset A, Newman M E J and Moore C, 2004 Phys. Rev. E 70 066111.

Wakita K and Tsurumi T, 2007 Proceedings of IADIS international conference on WWW/Internet 2007 153.

Pons P and Latapy M, 2006 Journal of Graph Algorithms and Applications 10 191.

# Advantages

Incredibly simple (local greedy approach) $\Rightarrow$  easy to implement and to improve

Very fast!

Good accuracy

# Advantages

Incredibly simple (local greedy approach) $\Rightarrow$  easy to implement and to improve

Very fast!

Good accuracy

	Karate	Arxiv	Internet	Web nd.edu	Phone	Web uk-2005	Web WebBase 2001
Nodes/links	34/77	9k/24k	70k/351k	325k/1M	2.04M/5.4M	39M/783M	118M/1B
CNM	.38/0s	.772/3.6s	.692/799s	.927/5034s	-/-	-/-	-/-
PL	.42/0s	.757/3.3s	.729/575s	.895/6666s	-/-	-/-	-/-
WT	.42/0s	.761/0.7s	.667/62s	.898/248s	.553/357s	-/-	-/-
Our algorithm	.42/0s	.813/0s	.781/1s	.935/3s	.76/41s	.979/738s	.984/152mn

# Advantages

Incredibly simple (local greedy approach) $\Rightarrow$  easy to implement and to improve

Very fast!

Good accuracy

On ad hoc networks with a well-known community structure:

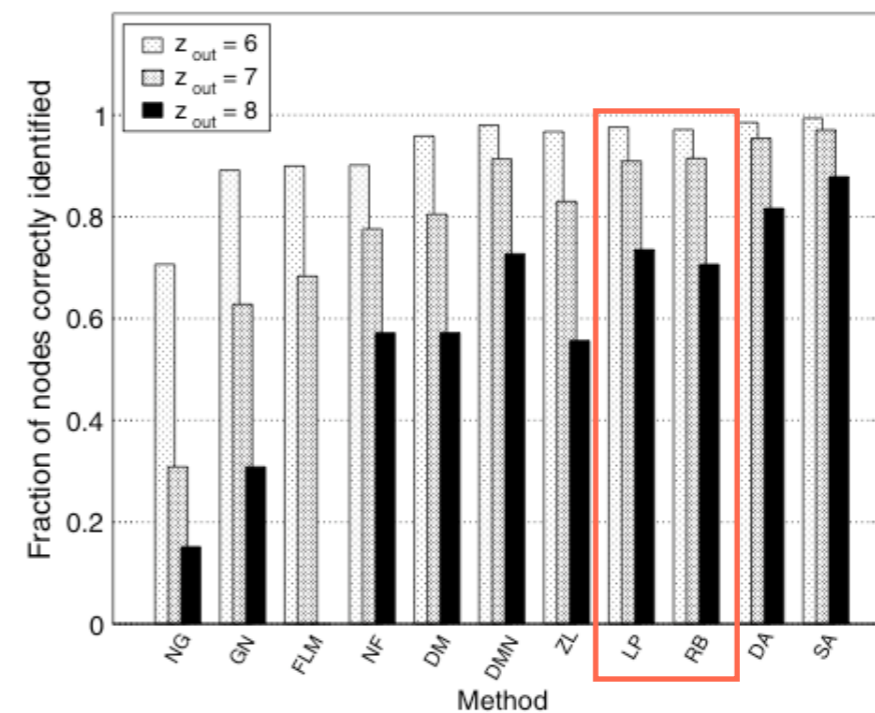
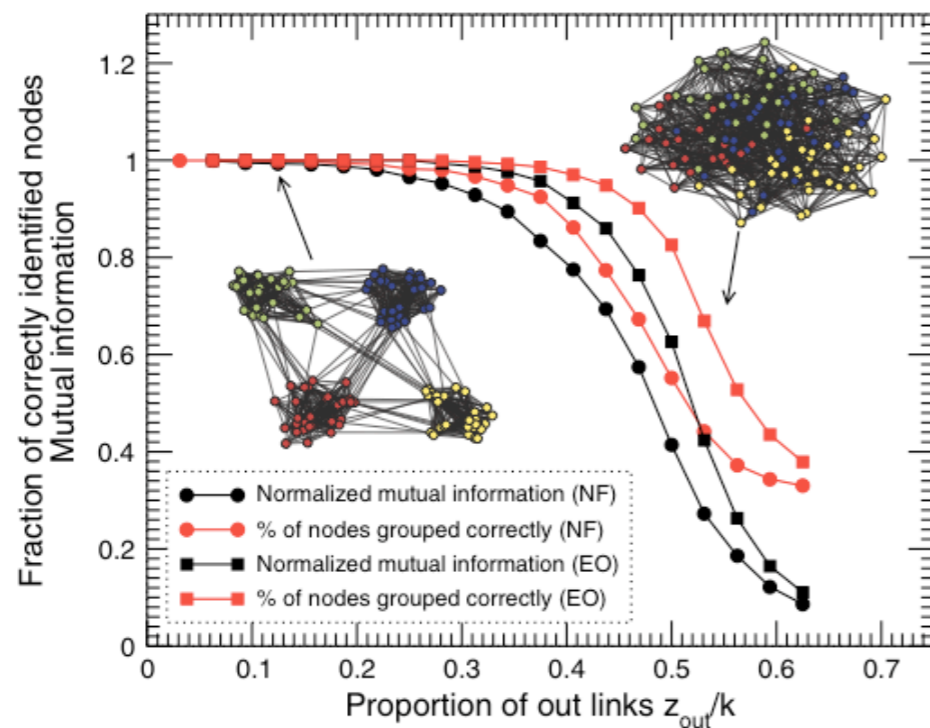

# Advantages

Incredibly simple (local greedy approach) $\Rightarrow$  easy to implement and to improve

Very fast!

Good accuracy

Multiresolution

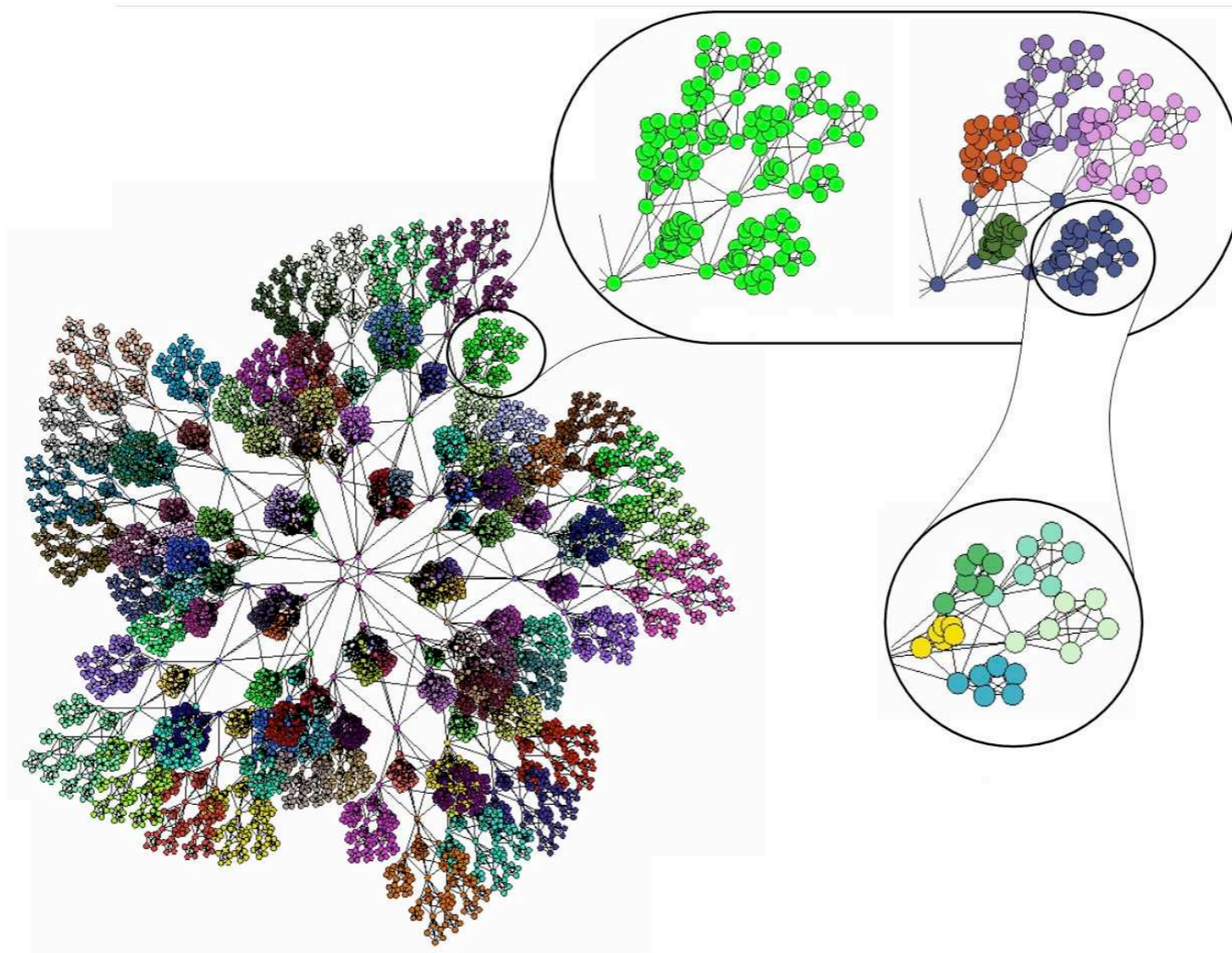

# Conclusion

- Can deal with millions/billions nodes/links
- Achieves very good modularity
- Directly produces a hierarchy structure;
- Is strikingly simple;
- Can use other local quality functions (instead of modularity);
- C++ and matlab available on [findcommunities.googlepages.com](http://findcommunities.googlepages.com)